

Drawing Number: 7149
Product Code: SLF600 - 6000
SLF600N - 6000N

Permutation :

**Ladder Modular Fixed SS-PE. Rung width 300mm
or 400mm**

Type of Test

TYPE TEST

Standard Tested to

EN14396:2004 (including Annex ZA)

Ladder Specification

Fixed modular ladder to be used in underground concrete rings, chambers or other structures.

Product Image



Approved by

Name: A. Turner
Signature: *A. Turner*
Position: Technical manager
Issue date: 16th September 2014

The results in this test report apply only to the samples tested, using the method tested as detailed in this report. This test report does not indicate certification or approval of any product to any standard. This report may not be used to advertise any product without written consent from the Managing Director of Caswick Ltd. Caswick Ltd have to right to refuse the publication of this report to any person(s) without giving reason. Caswick reserve the right to change the information in this report at any time.

All test results given in this document are taken from a random step sample. The step is picked at random from normal production and tested in accordance with standard EN13101. Although routine random sample testing is carried out to ensure our products meet the highest standard, due to variations beyond our control the results given here may vary slightly to the product supplied to you. All steps will comply with EN13101.

Content	Product Overview	Page 1
	Intended Use	Page 1
	Product Drawing	Page 2
	Materials	Page 3
	Type	Page 3
	Typical Results:	
	Dimension Check	Page 4
	Surface Condition	Page 5
	Threaded Joints	Page 5
	Welded Joints	Page 5
	Rungs	Page 5
	Attachment to Manhole	Page 5
	Vertical Imposed load on Rungs	Page 6
	Ladder Strength	Page 7
	Anchorage Point	Page 8
	Marking	Page 8
	Instructions for Installation and Use	Page 9
	Evaluation of Conformity	Page 9

Product Overview	400mm rung width 300mm rung width with 'N' denotation 150mm, 200mm, 250mm or 300mm nominal projection by order bright colour
-------------------------	---

Intended use	Incorporating into concrete structures. Fitting methods; - Cast in - Drill and glue - Insertion into wet concrete
---------------------	--

Product Drawing

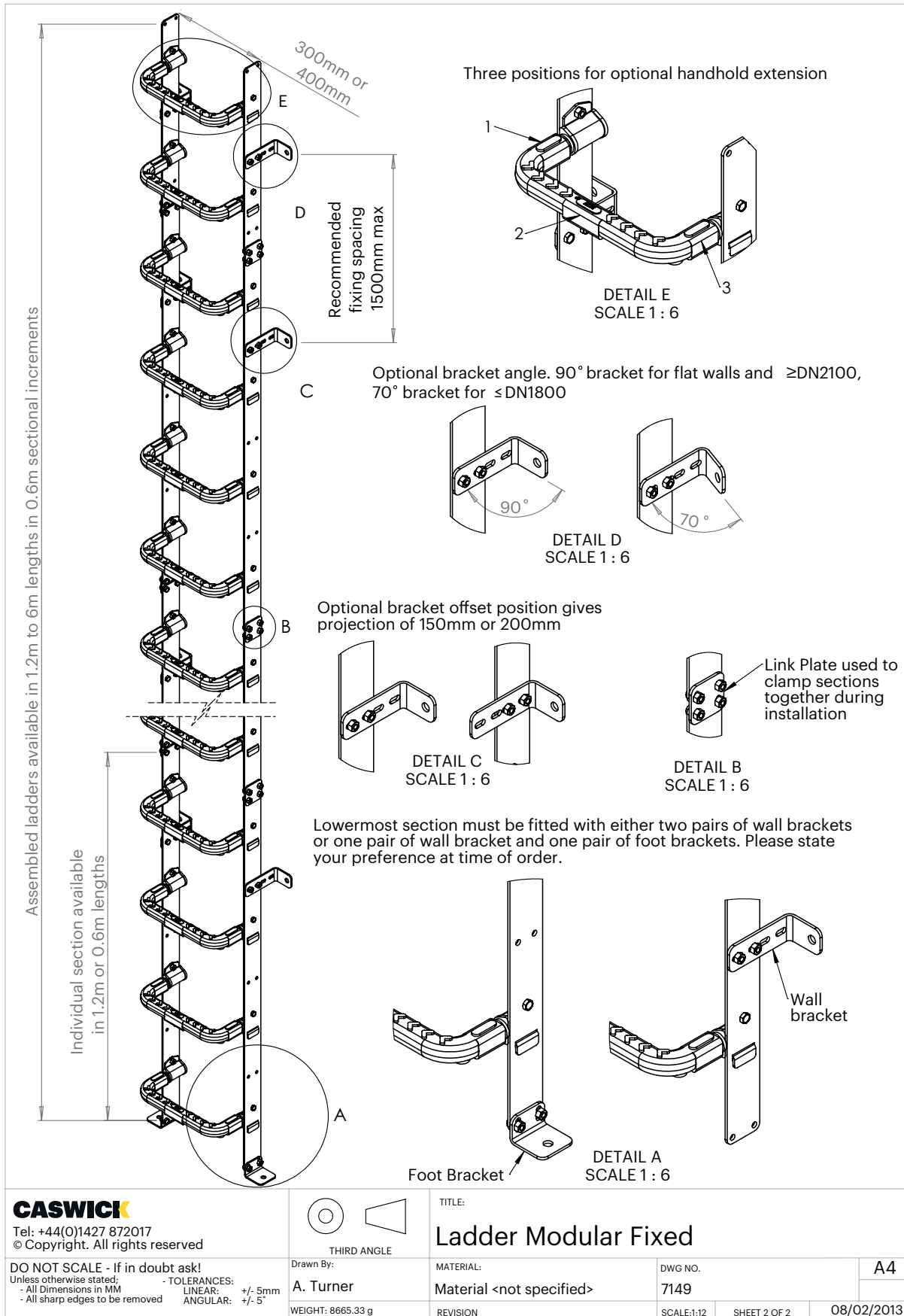

Materials

Section 4.2

Where appropriate the step materials shall conform to the following;

Type	Required Standard	Actual Standard
Steel	Steel to EN 10025 or ENV 10080:1995 or current equivalent and hot dip galvanised to EN ISO 1461 with thickness as outlined in table 1 EN14396	EN10305 coated with PP Block Copolymer High Impact grade*
	Stainless steel to EN10088-1 or EN10088-3 grade X6CrNiTi18-10 (321) NOTE 321 is 304 with added titanium to resist intergranular corrosion.X6CrNiMoTi17-12-2 (316Ti) recommended for sewage or drinking water.	304, 316 by special order.
GRP	To EN 13706 and UV resistant to Annex A EN14396.	N/A

*An approved corrosion resistance method in EN13101 and tested to the relevant requirement of this standard.

EN 14396:2004 Type

Requirement – Section 4.3.1

Requirement

Steps shall be one of the following types;

Type A – Fixed ladder with movable top extensions

Type B – Fixed ladder with two stringers and fall arrester

Type C – Fixed ladder with one stringer and fall arrester

Type D – Fixed ladder with two stringers

Type D – Fixed ladder with one stringer

Result

The ladder is a type D

EN 14396:2004 Dimension Check Requirement – Section 4.3.2

Requirement

When measured at the points shown on the diagram below, the dimensions must be within the range set in the table below.

Result

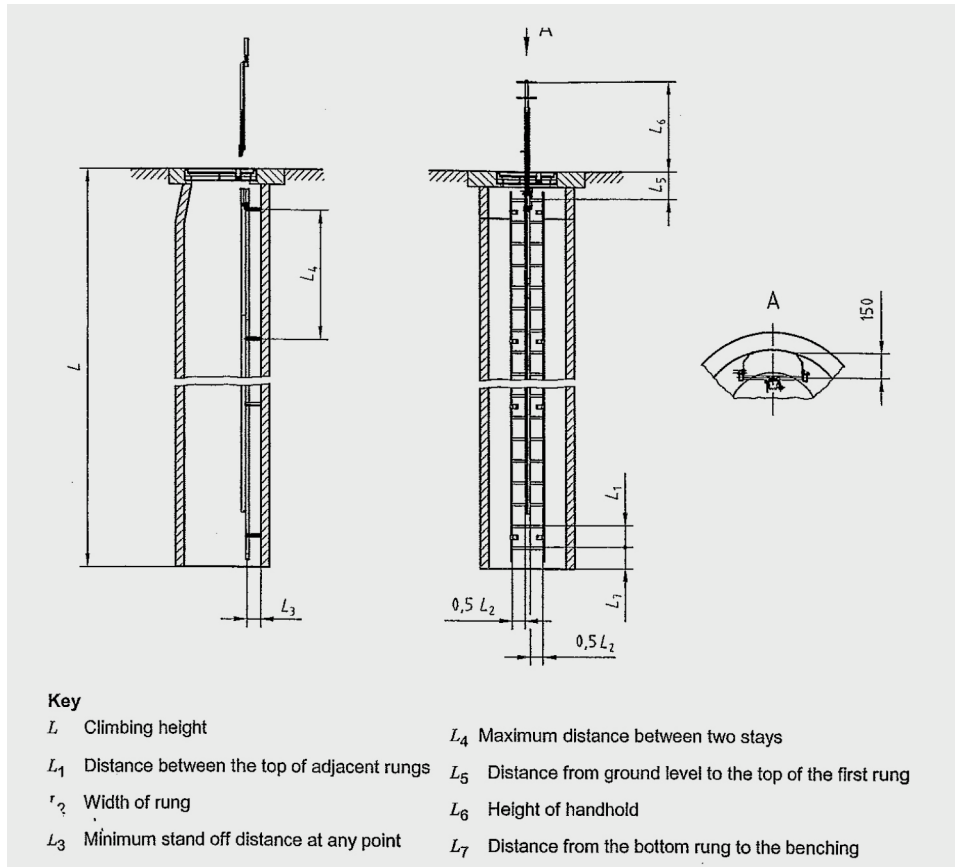

Tolerance	L1	L2	L3	L4	L5	L6	L7
Min	250	300	150	-	-	1000	≤L1
Max	300	-	-	b	L1a	-	
Actual	300	300/400	150+	≤1500	>120c	≤1000	≥175c

- a In special cases (e.g. where the manhole design so requires). For the installation national provisions valid in the place of use shall be taken into account.
- b To be stated by the manufacturer but not more than 3000mm.
- c Defined by installer, dimension quoted defines achievable range.

EN 14396:2004 Surface Conditions: Requirement – Section 4.3.3

Is the ladder free from visible defects, protrusions and sharp edges?

Yes No

EN 14396:2004 Threaded Joints: Requirement – Section 4.3.4

Are threaded joints designed such that they cannot work loose?

Yes No

Note: Achieved by nylon locking nuts

EN 14396:2004 Welded Joints: Requirement – Section 4.3.5

N/A

**EN 14396:2004 Rungs Requirement – Section 4.3.6
Procedure – Annex A**

Requirement:

Flat treads shall be at least 20mm wide.
Circular treads shall be at least 20mm diameter but not greater than 45mm.
U-shaped rungs shall be at least 20mm deep.
For other forms the maximum circumferential length shall be 140mm.

Results:

Is the surface slip resistant? Yes No

Does the ladder have either two stringers or 20mm high boot stops? Yes No

EN 14396:2004 Attachment to Manhole Requirement – Section 4.3.7

For ladders with two stringers, does each section shall have at least four stays and anchorage points?

Yes No

Note: Ladder has two fixings to the wall and two to the adjacent section.

Is the top stay located below the top rung but not by more than 600mm?

Yes No

Is the bottom stay located below the second rung from the ladder bottom?

Yes No

EN 14396:2004 Vertical Imposed

Load on Rungs:

Requirement – Section 4.3.8

Procedure – Annex B

Requirement:

The rung shall have a permanent deflection of no more than 0.3% of its unsupported length after an applied test load of 2.6kN.

Results:

0.3% of unsupported length for 350 ladder =

$$62 + \left(\frac{11.76}{4}\right) + 244 + \left(\frac{11.76}{4}\right) + 62 \times 0.003 = 1.46\text{mm}$$

First test cycle residual deflection 3.41mm

Second test cycle residual deflection 0.60mm

This is due to the nature of the design, the first test cycle removes all of the slack from the assembly tolerance build up. The second test tests the strength of the actual components.

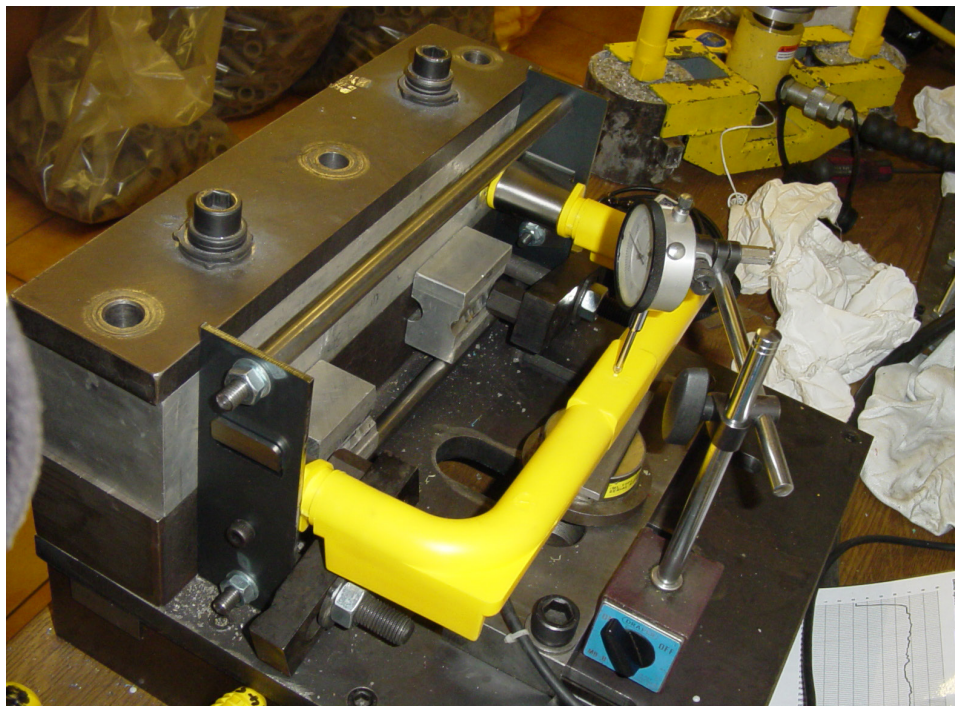

EN 14396:2004 Ladder Strength

Requirement – Section 4.4.3.2.1

Procedure – Annex C

Requirement

The ladder shall have a permanent deflection of no more than 0.3% of its unsupported length after an applied test load of F_3' when tested in accordance with Annex C EN14396.

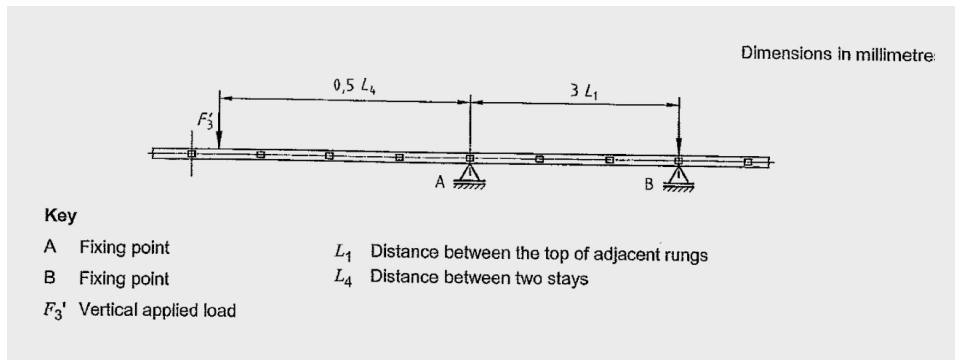

Results:

$F_3' = 0.4\text{kN} \times 1.75$ (safety factor for steel) = 0.7kN

$0.5 \times L_4$ (maximum distance between fixings) = 0.75m

Permanent deflection limit = 0.3% of 0.75m = 2.25mm

Load (kN)	Deflection (mm)
0.0	0.00
0.7	8.62
0.0	0.43



EN 14396:2004 Anchorage Points: Requirement – Section 4.4.4.2
 Procedure – Annex E/F

Requirement: Fixings of ladders with two stringers are to withstand a 3kN load applied in accordance with Annex E of EN14396.

Results: The first installed section has 4 off wall fixings, subsequent sections have 2 off wall fixings and 2 off fixings to the previous section.

Determination of fixing load bearing capacity;

Assumptions;

- Load is to be held by two fixings 1500mm apart
- Ladder has the worst case load offset of 200mm

1. Direct shear force to be held per fixing is applied force of 3kN per stringer.

2. Pullout force on upper fixing through assumption that rotation will occur through pivoting around lower bracket;

Applied moment = 3,000N x 0.2m = 600Nm

Resultant force = 600Nm / 1.5m = 400N.

Using a safety factor of 4 the required fixing must withstand a pullout of 1.6kN and shear of 12kN.

Anchor SLB14/10SS will withstand a shear of 14.5kN and pullout of 12.6kN when tightened to 50Nm in C20/25 concrete or stronger.

Marking: Section 5

The following shall be visible after installation;

Marking Requirements

Manufacturers identification

Present?

Yes No

Last two digits of year of manufacture

Yes No *

Type

Yes No

Maximum distance between two anchorage points

Yes No

*On underside of rung

Additional marking on this product (for information purposes only);

CE Mark next to manufacturers name?

Yes No

Third party certification body (BSI Kitemark)?

Yes No

Instructions for Installation and Use :

Section 5

The following shall be visible after installation;

Instructions contain the following;

- Pullout requirements of anchors
- Intended use of ladder

Evaluation of Conformity :

Section 7

- Initial type testing (this document)
- Factory Production Control. Caswick operate an FPC system for the manufacture of ladders including;
 - Documentation of raw materials and components
 - Inspection of received components
 - Testing of manufactured components